

**AMERICAN
METER COMPANY**

SB-8515.7

1800C & 1800C-HC Service Regulators

Maximum Inlet Pressure 125 PSIG



AMC Quality System
QMI is Accredited by:



ISO 9001 Certified
Certificate #006697



Dutch Council
for Accreditation

DMC 多美時燃氣設備有限公司
DMC GAS EQUIPMENT LIMITED

Address: Unit 11, 11/F, Tower One, Ever Gain Plaza
88 Container Port Road, Kwai Chung, NT, Hong Kong

Website: www.dmc-gas.com

Email: dmcsaleshk@dmc-gas.com.hk

Tel: +852 2851 2121

Fax: +852 2851 2129

1800C Service Regulators

General Information

The American Meter Series 1800C pressure regulators are designed for natural gas applications and features a compact, lightweight design for fast, easy installation. Interchangeable orifices and springs provide a wide range of outlet pressures and flow rates. Outlet pressures between 3.5" W.C. and 2 PSIG are available. Operating temperature range is -20° F to 150° F (-30° C to 65° C). Maximum flow rate is 2500 SCFH (70.8 m³/h).

The diaphragm case may be easily removed for routine inspection without disturbing the line connections. All models conform to ANSI Code B109.4-1998, and CGA Service-type Regulator Specification CAN/CGA-6.18-M95.

Exclusive, 7 - Step Corrosion Protection

The protective finish on the Series 1800C regulators resists corrosive effects of weather and harsh environments better than any other in the industry. Each precision die cast aluminum regulator is treated-inside and out-with a special conversion coating that's part of an exclusive, 7-step finishing process. This coating greatly inhibits oxidation of the metal's surface that can eventually compromise the integrity of the metal. It also prevents finish paint from cracking and blistering.

A single coat polyester primer and the high solid polyurethane top coat provides a long-lasting protection to all exterior regulator surfaces. The American Meter conversion coating process meets all environmental protection regulations.

High Tensile Strength Valve Bodies

Each Series of 1800C regulator is equipped with a high tensile strength cast iron valve body that rotates in 90-degree increments and features extra heavy wall thickness. This provides maximum strength to withstand installation stresses without damage and prevents thread galling experienced with aluminum.

Series 1800C regulator valve bodies are treated with a 5-step metal finishing process. The treated metal is painted with a single coat polyester paint.

Available valve body sizes are: 3/4" x 3/4", 3/4" x 1", 3/4" x 1-1/4", 1" x 1", 1" x 1-1/4" and 1-1/4" x 1-1/4" NPT or BSP-TR. Also available is a offset valve body in 3/4" x 3/4", 3/4" x 1" and 1" x 1" NPT or BSP-TR.

Application

Models 1813C and 1843C features a full capacity internal relief valve with large passages to assure the fast release of gas (See performance graphs on page 6). For added protection, a relief valve stop is provided to assure operation under the most severe conditions. The standard relief spring setting is 8.0" W.C. above the normal 7" W.C. outlet pressure.

Models 1843C are equipped with overpressure shut-off (OPSO) that provide protection against downstream

overpressure. Valve body configuration permits the 1800C Series regulators to be supplied in four positions as specified on page 9. All Series 1800C regulators are available with either right angle (90 degree) or straight flow (180-degree) valve bodies. Vents can also be supplied in four different positions.

All models are designed with an extra large, removable weather and bug-proof stainless steel screened vent to resist freeze-ups and to exclude foreign matter. The vent is threaded 3/4 or 1 inch NPT and is also available with BSP-TR threads making it suitable for indoor installations.

Options

Vent Elbow- The regulator vent opening should face downward (6 o'clock) **to minimize the chance of blockage from ice and snow.** If not, a 3/4" NPT plastic, 90° vent elbow (Part number 78041P025) and separate protective screen (Part number 70400P017) may be screwed into the vent to provide the necessary protection.

Elevation Compensation- E.C. orifices are also available, which provide constant outlet pressure even when inlet pressure fluctuates greatly. The elevation compensation orifice is a device which reduces changes in regulator outlet pressure due to change in inlet pressure.

The E.C. orifice is recommended for installations where the inlet pressure may vary over a wide range. The E.C. orifice is available in two sizes: 1/8" x 3/16" (Part number 73698G006) and 3/16" (Part number 73698G005). Its capacity is the same as a standard orifice of the same size. Consult your American Meter Sales Representative for specific applications.



① AC-250 Meter

② 1813C Regulator

Website: www.dmc-gas.com
Email: dmcsaleshk@dmc-gas.com.hk

1800C-HC Service Regulators



General Information

Ideal for light commercial and industrial use, the 1-1/4" 1800C-HC Series regulator is designed to increase output capacity and lessen compounding during medium- to high-inlet pressure operations. Compounding usually occurs when a larger valve body introduces undesirable flow characteristics, thereby creating an inefficient, boosting effect in the outlet port of the body.

The 1800C-HC regulator's lightweight design features high-capacity capabilities for 1-1/4" NPT connections and flow capacities up to 4900 SCFH depending on inlet pressure and orifice selection. It complements the 1800C Series family of regulators.

A lightweight regulator designed to increase capacity output and minimize the outlet boosting effect that is typical from a larger valve body.

All models conform to ANSI Code B109.4-1998 and CGA Service-type Regulator Specification CAN/CGA-6.18-M95.

1813C-HC-180° Dimensions

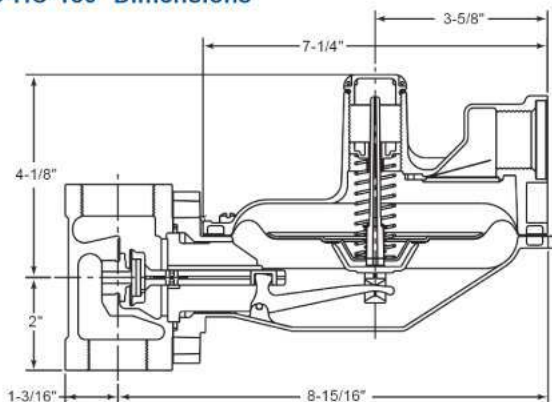

1843C-HC Dimensions

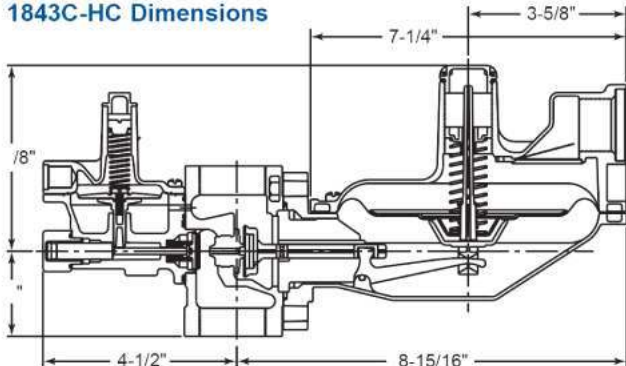

① AC-630 Meter

② 1813C-HC Regulator

Website: www.dmc-gas.com

Email: dmcsaleshk@dmc-gas.com.hk

1800C Service Regulators

Model 1813C-90°

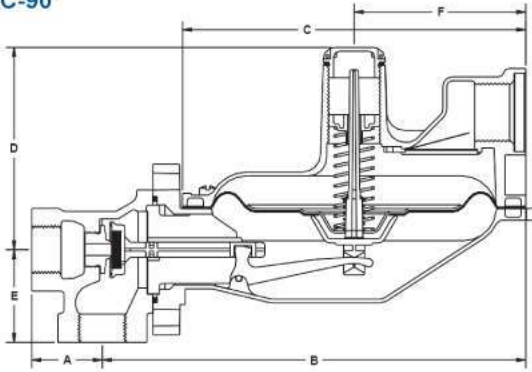

Model 1813C-180°

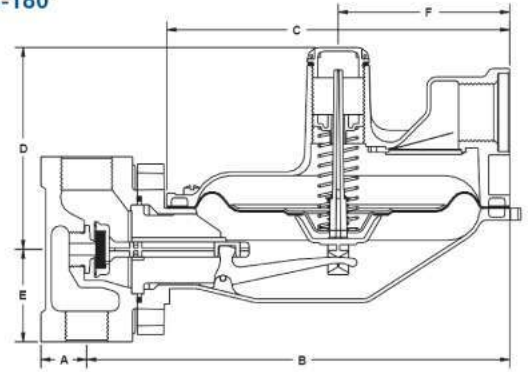

Model 1843C

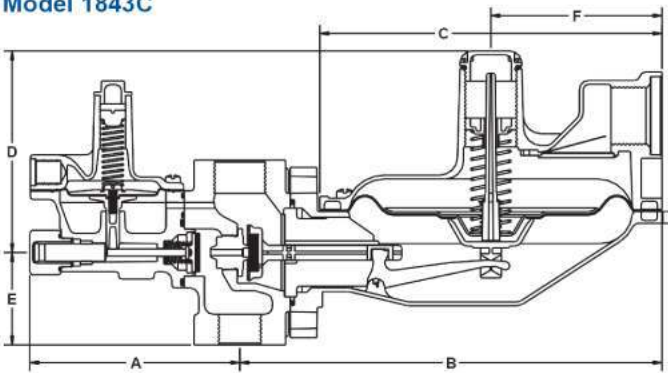

Model 1813C-Offset

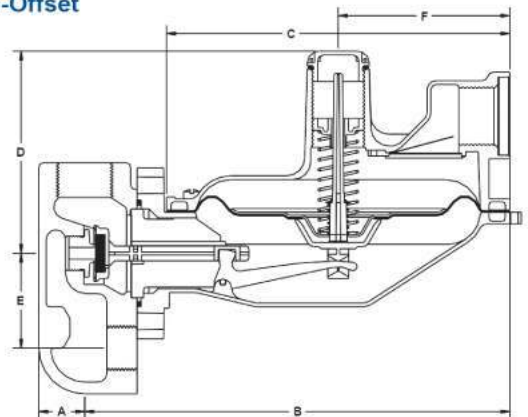

Dimensions Model 1813C

Inlet	Outlet	A			B	C	D	E	Offset	F
		90°*	180°*	Offset						
3/4"	3/4"	1-9/16"	1"	1"	8-7/8"	7-14"	4-1/8"	2"	2"	3-5/8"
3/4"	1"	1-9/16"	1"	1"	8-7/8"	7-1/4"	4-1/8"	2"	2"	3-5/8"
1"	1"	1-9/16"	1"	1"	8-7/8"	7-1/4"	4-1/8"	2"	2"	3-5/8"
1"	1-1/4"	—	1-1/8"	—	8-7/8"	7-1/4"	4-1/8"	2"	—	3-5/8"
1-1/4"	1-1/4"	—	1-1/8"	—	8-7/8"	7-1/4"	4-1/8"	2"	—	3-5/8"
3/4"	1-1/4"	—	1-1/8"	—	8-7/8"	7-1/4"	4-1/8"	2"	—	3-5/8"

Dimensions Model 1843C

Inlet	Outlet	A	B	C	D	E	F
3/4"	3/4"	4-1/2"	8-15/16"	7-1/4"	4-1/8"	2"	3-5/8"
3/4"	1"	4-1/2"	8-15/16"	7-1/4"	4-1/8"	2"	3-5/8"
1"	1"	4-1/2"	8-15/16"	7-1/4"	4-1/8"	2"	3-5/8"
1"	1-1/4"	4-1/2"	8-15/16"	7-1/4"	4-1/8"	2"	3-5/8"
1-1/4"	1-1/4"	4-1/2"	8-15/16"	7-1/4"	4-1/8"	2"	3-5/8"

DMC 多美時燃氣設備有限公司
DMC GAS EQUIPMENT LIMITED

Address: Unit 11, 11/F, Tower One, Ever Gain Plaza

88 Container Port Road, Kwai Chung, NT, Hong Kong

Website: www.dmc-gas.com

Email: dmcsaleshk@dmc-gas.com.hk

Tel: +852 2851 2121

Fax: +852 2851 2129

Overpressure Shut-off Regulator

Overpressure Shut-off (OPSO) Regulators

Models 1843C and 1843C-HC regulators are compact units designed to regulate line pressure and to provide protection against any downstream overpressure.

Rugged, Compact OPSO - Operates independently. The OPSO will shut-off the gas supply in the event of a serious downstream pressure build-up.

Adjustable Overpressure Shut-off - Pressure is adjustable via the overpressure shut-off adjustment screw to settings from 14" to 35" W.C. and 1 to 3-1/2 PSIG depending on spring selected.

Extra Safety - Models 1843C and 1843C-HC provides added protection by incorporating a full capacity relief valve. This internal valve is the same as in the 1813C and 1813C-HC and operates in the same manner to combine safety features.

How The OPSO Operates

When the outlet pressure exceeds the OPSO set point, the pressure under the OPSO diaphragm (A) compresses the pressure spring (B) forcing the diaphragm stem (E) upwards and releasing plunger (D). This permits the shut-off spring (F) to force the shut-off disc (G) against the back side of the special double ended orifice.

Shut-off Assembly

72978G070
72978G071

Adjustable Trip Point Range

14" to 35" W.C.
1 to 3-1/2 PSIG

Note: When selecting the shut-off spring range, a differential of 14" W.C. above the normal operating pressure and the shut-off pressure is recommended for normal line pressure variations. The OPSO setting is preset at the factory to the desired trip point.

To reset the OPSO simply unscrew cap (C), pull back the plunger (D) until the diaphragm stem (E) repositions.

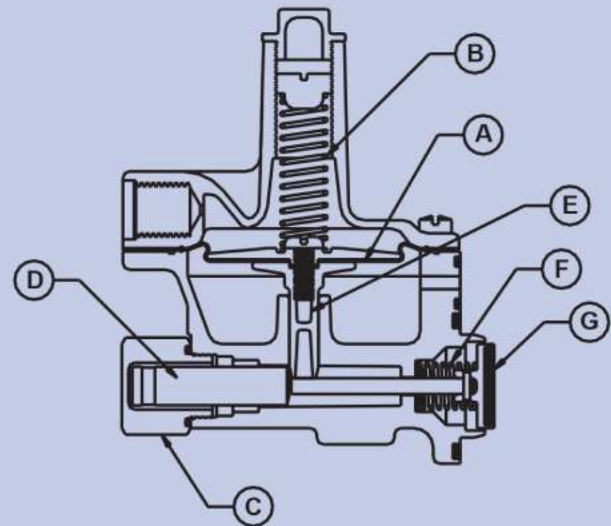
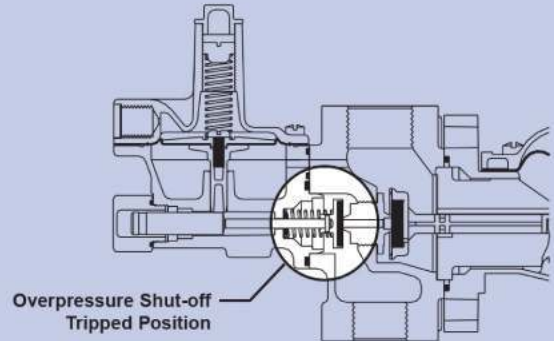

1800C & 1800C-HC Service Regulators

Full Open Regulator Relief Capacity

For sizing downstream relief valves, use the following formulas to determine the regulator full open capacity:

For critical flow rates

$$Q = 0.5 C \times \frac{P_1}{\sqrt{G}}$$

For sub-critical flows

$$Q = C \frac{\sqrt{P_2 h}}{\sqrt{G}}$$

Key:

- Q = Maximum capacity of regulator
- C = Orifice constant, see table
- P₁ = Inlet absolute pressure (PSIA)
- P₂ = Outlet absolute pressure (PSIA)
- h = Differential pressure (P₁ - P₂)
- G = Specific gravity of gas

Orifice	C
1/8"	25
1/8" x 3/16"	25
3/16"	57
1/4"	98
5/16"	149
3/8"	208
1/2"	353
9/16"	421

DMC 多美時燃氣設備有限公司
DMC GAS EQUIPMENT LIMITED

Address: Unit 11, 11/F, Tower One, Ever Gain Plaza,
88 Container Port Road, Kwai Chung, NT, Hong Kong

Website: www.dmc-gas.com

Email: dmcsaleshk@dmc-gas.com.hk

Tel: +852 2851 2121

Fax: +852 2851 2129

1800C Service Regulators

1800C Regulator Capacity Performance

Capacity 3/4" Outlet 1800C Regulator Set Point 7.0" W.C. @ 50 SCFH

SCFH 0.60 specific gravity gas @ 60° F & 14.7 PSIA. Pressure spring 70017P044. Outlet pressure variance not to exceed +2" -1" W.C. from set point, horizontal position.

Inlet (PSIG)	Orifice Size						
	1/8 x 3/16	3/16	1/4	5/16	3/8	1/2	9/16
1		175	250	325	350	400	400
2		300	425	475	550	650	650
3		375	500	600	700	800	800
5	275	500	700	800	950	1000	1200
10	375	750	1100	1200	1400	1500	1700
15	450	950	1400	1500	1600	1900	2000
20	500	1100	1700	1700	1900	2200	2300
30	700	1400	2000	2200	2400	2500	
40	800	1700	2400	2500	2500		
60	1100	2300	2500	2500			
100	1700	2500	2500				
125	2100						

For optimum performance, maximum inlet pressure should not exceed maximum capacity rating for any given orifice size.

Capacity 1" Outlet 1800C Regulator Set Point 7.0" W.C. @ 50 SCFH

SCFH 0.60 specific gravity gas @ 60° F & 14.7 PSIA. Pressure spring 70017P044. Outlet pressure variance not to exceed +2" -1" W.C. from set point, horizontal position.

Inlet (PSIG)	Orifice Size						
	1/8 x 3/16	3/16	1/4	5/16	3/8	1/2	9/16
1		175	250	300	375	475	500
2		250	350	450	500	600	650
3		300	450	550	700	850	950
5	250	450	650	750	950	1200	1300
10	350	700	1000	1400	1600	1900	2000
15	425	900	1400	1900	2100	2500	2500
20	500	1100	1700	2300	2500	2500	
30	600	1400	2300	2500	2500		
40	750	1700	2500	2500			
60	1000	2400	2500				
100	1600	2500					
125	2000						

For optimum performance, maximum inlet pressure should not exceed maximum capacity rating for any given orifice size.

Capacity 1-1/4" Outlet 1800C Regulator Set Point 7.0" W.C. @ 50 SCFH

SCFH 0.60 specific gravity gas @ 60° F & 14.7 PSIA. Pressure spring 70017P044. Outlet pressure variance not to exceed +2" -1" W.C. from set point, horizontal position.

Inlet (PSIG)	Orifice Size						
	1/8 x 3/16	3/16	1/4	5/16	3/8	1/2	9/16
1		200	325	350	375	475	500
2		325	500	600	700	950	1400
3		425	650	950	1200	1700	1900
5	275	550	1000	1600	2100	2500	2500
10	375	850	1500	2400	2500	2500	2500
15	450	1000	1800	2500			
20	550	1200	2100				
30	700	1600					
40	800						
60	1100						
100	1400						

For optimum performance, maximum inlet pressure should not exceed maximum capacity rating for any given orifice size.

Capacity 3/4" Outlet 1800C Regulator Set Point 2 PSIG @ 50 SCFH

SCFH 0.60 specific gravity gas @ 60° F & 14.7 PSIA. Pressure spring 70017P049. Outlet pressure variance not to exceed +/- 10% from set point, horizontal position.

Inlet (PSIG)	Orifice Size						
	1/8 x 3/16	3/16	1/4	5/16	3/8	1/2	9/16
3	150	175	300	325	375	400	500
5	250	325	450	525	575	700	750
10	375	550	700	825	1000	1200	1300
15	450	750	900	1100	1300	1500	1800
20	550	900	1200	1300	1600	1900	
30	700	1200	1500	1800	2100		
40	850	1500	2000	2200			
60	1100	2100	2500				
100	1700	2500					
125	2100						

For optimum performance, maximum inlet pressure should not exceed maximum capacity rating for any given orifice size.

Capacity 1" Outlet 1800C Regulator Set Point 2 PSIG @ 50 SCFH

SCFH 0.60 specific gravity gas @ 60° F & 14.7 PSIA. Pressure spring 70017P049. Outlet pressure variance not to exceed +/- 10% from set point, horizontal position.

Inlet (PSIG)	Orifice Size						
	1/8 x 3/16	3/16	1/4	5/16	3/8	1/2	9/16
3	150	225	250	350	425	550	550
5	225	350	450	500	650	750	900
10	350	600	750	850	1000	1300	1500
15	425	800	1000	1100	1400	1700	2000
20	500	1000	1200	1400	1800	2100	
30	650	1300	1700	2000	2500		
40	800	1700	2200	2500			
60	1100	2500	2500				
100	1700	2500					
125	2100						

For optimum performance, maximum inlet pressure should not exceed maximum capacity rating for any given orifice size.

Capacity 1-1/4" Outlet 1800C Regulator Set Point 2 PSIG @ 50 SCFH

SCFH 0.60 specific gravity gas @ 60° F & 14.7 PSIA. Pressure spring 70017P049. Outlet pressure variance not to exceed +/- 10% from set point, horizontal position.

Inlet (PSIG)	Orifice Size						
	1/8 x 3/16	3/16	1/4	5/16	3/8	1/2	9/16
3	150	225	350	375	425	550	550
5	225	350	500	600	700	900	1100
10	350	600	850	1100	1200	1700	2200
15	425	850	1200	1600	1900	2500	2500
20	500	1000	1700	2200	2500	2500	
30	650	1500	2500	2500	2500		
40	800	1900	2500	2500			
60	1100	2500	2500				
100	1700	2500					
125	2100						

For optimum performance, maximum inlet pressure should not exceed maximum capacity rating for any given orifice size.

1800C-HC Service Regulators

1800C-HC Regulator Capacity Performance

Capacity 1-1/4" Outlet 1800C-HC Regulator Set Point 7.0" W.C. @ 50 SCFH

SCFH 0.60 specific gravity gas @ 60° F & 14.7 PSIA. Pressure spring 70017P044. Outlet pressure variance not to exceed +2" -1" W.C. from set point, horizontal position.

Inlet (PSIG)	Orifice Size						
	1/8 x 3/16	3/16	1/4	5/16	3/8	1/2	9/16
1		175	200	250	350	475	525
2		275	350	450	525	675	800
3		350	450	600	750	800	1100
5	275	450	700	850	1000	1500	1600
10	350	600	1100	1500	1600	2500	2700
15	425	950	1300	2300	2600	3300	3300
20	475	1100	1900	2900	3400	4200	3900
30	600	1500	2500	4000	4600	4900	
40	750	1800	3200	4900	4900		
60	1100	2500	4400	4900			
100	1600	3800					
125	2000						

For optimum performance, maximum inlet pressure should not exceed maximum capacity rating for any given orifice size.

1800C & 1800C-HC Service Regulators

Pressure Springs

Outlet Pressure	Color Code	Part Number 1813B2
3.5" to 6" W.C.	Blue	70017P043
3.5" to 7.5" W.C.	Tan	70017P089
5.5" to 8.5" W.C.	Yellow	70017P044
6" to 15" W.C.	Purple	70017P042
12" to 28" W.C.	White	70017P060
24" to 48" W.C.	Red	70017P082
42" W.C. to 2 PSIG	Red-Red	70017P049

Maximum Recommended Inlet Pressure

Orifice Size	Inlet Pressure (PSIG)
9/16"	20
1/2"	50
3/8"	70
5/16"	125
1/4"	125
3/16"	125
1/8" x 3/16"	125
1/8"	125

Orifice Sizes

Orifice Size	Part Number	
	Standard	w/ OPSO
9/16"	72494P026	72751P019
1/2"	72494P025	72751P016
3/8"	72494P023	72751P014
5/16"	72494P022	72751P013
1/4"	72494P021	72751P012
3/16"	72494P020	72751P011
1/8" x 3/16"	72494P030	72751P020
1/8"	72494P019	N/A

See page 5 for capacity performance for each orifice size.

DMC 多美時燃氣設備有限公司
DMC GAS EQUIPMENT LIMITED

Address: Unit 11, 11/F, Tower One, Ever Gain Plaza,
88 Container Port Road, Kwai Chung, NT, Hong Kong

Website: www.dmc-gas.com

Email: dmcsaleshk@dmc-gas.com.hk

Tel: +852 2851 2121

Fax: +852 2851 2129

1800C & 1800C-HC Service Regulators

Regulator Relief Valve Performance

There are several methods of measuring the relief performance of a regulator. The worst case scenario will occur when the lever is disconnected. The data presented in the tables below represent this condition.

Outlet Pressure Relative To Inlet Pressure

3/4" Screened Vent - No Vent Pipe
Set Pressure 7" W.C.

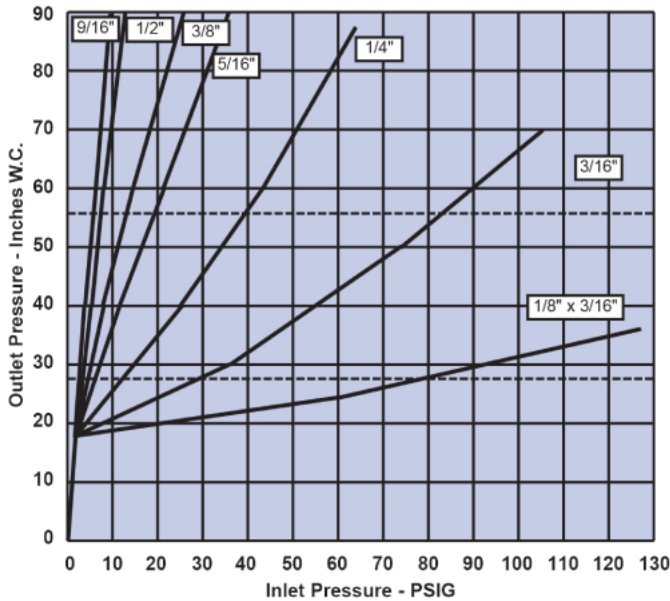

Outlet Pressure Relative To Inlet Pressure

1" Screened Vent - No Vent Pipe
Set Pressure 7" W.C.

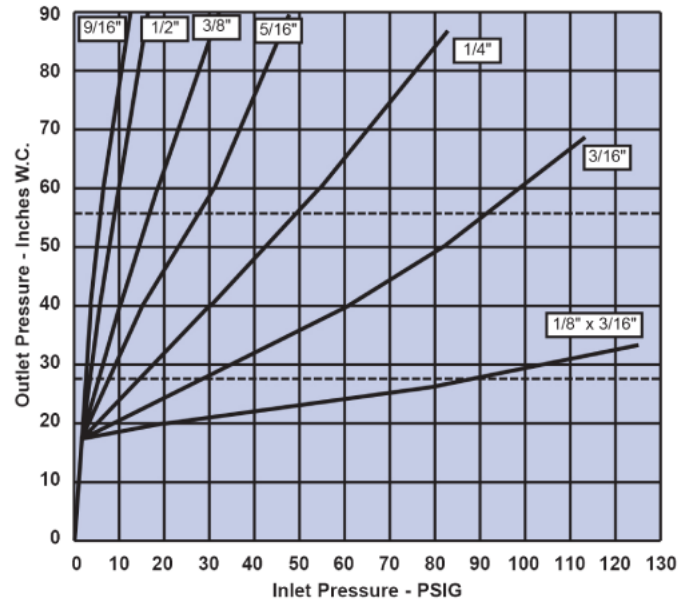

Outlet Pressure Relative To Inlet Pressure

3/4" Screened Vent - No Vent Pipe
Set Pressure 2 PSIG

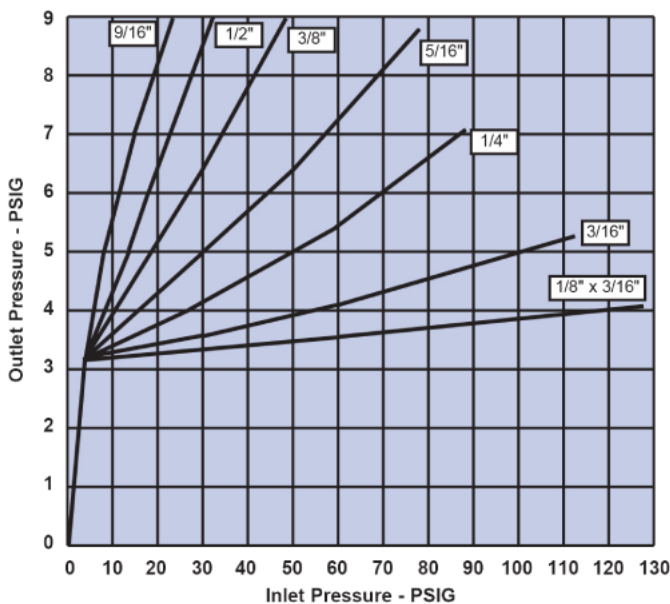

Outlet Pressure Relative To Inlet Pressure

1" Screened Vent - No Vent Pipe
Set Pressure 2 PSIG

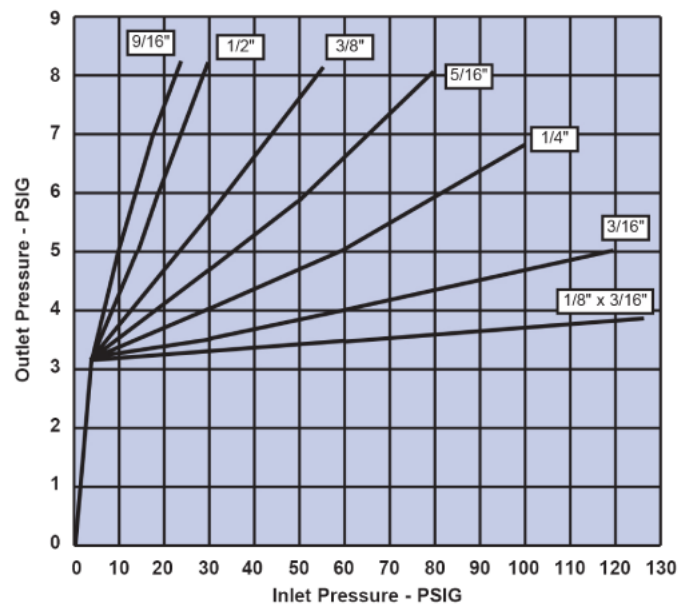

DMC 多美時燃氣設備有限公司
DMC GAS EQUIPMENT LIMITED

Address: Unit 11, 11/F, Tower One, Ever Gain Plaza,
88 Container Port Road, Kwai Chung, NT, Hong Kong

Website: www.dmc-gas.com Email: dmcsaleshk@dmc-gas.com.hk

Tel: +852 2851 2121

Fax: +852 2851 2129

1800C & 1800C-HC Service Regulators

Regulator Descriptions

Model Number	Description
1813C & 1813C-HC	Basic regulator with full capacity internal relief with 3/4" or 1" NPT vent.
1843C & 1843C-HC	Basic regulator with full capacity internal relief and overpressure shut-off and 3/4" or 1" NPT vent.
1853C w/ Jeavons & 1853C-HC w/ Jeavons *	Basic regulator with full capacity internal relief and overpressure, underpressure shut-off and 3/4" or 1" NPT vent.

* For Jeavons (USSA) operation, see Brochure SB-8556

Regulator Assembly Positions

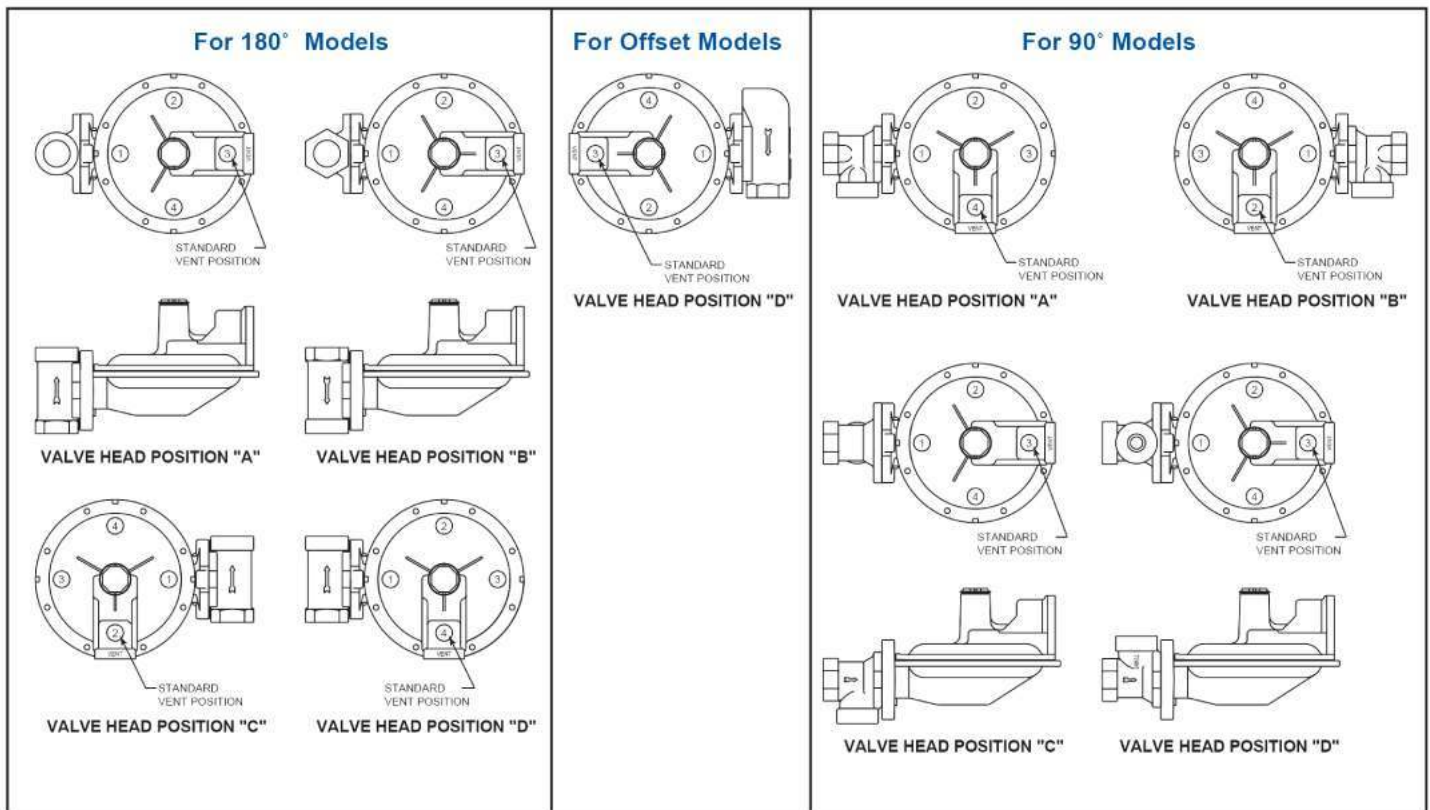

DMC 多美時燃氣設備有限公司
DMC GAS EQUIPMENT LIMITED

Address: Unit 11, 11/F, Tower One, Ever Gain Plaza

88 Container Port Road, Kwai Chung, NT, Hong Kong

Website: www.dmc-gas.com

Email: dmcsaleshk@dmc-gas.com.hk

Tel: +852 2851 2121

Fax: +852 2851 2129

1800C & 1800C-HC Service Regulators

Construction

Lower Diaphragm Case - Precision die cast aluminum with a exclusive 7-step advanced conversion coating, single coat polyester primer and High Solid Polyurethane Top Coat.

Top Assembly - Precision die cast aluminum with a exclusive 7-step advanced conversion coating, single coat polyester primer and High Solid Polyurethane Top Coat.

Valve Body - Cast grey iron, undercoated, single coat polyester primer and High Solid Polyurethane Top Coat, (Rotates in 90 degree increments).

Pressure Spring - Steel, Zinc plated and yellow chromate. Color coded for identification.

Diaphragm Plate - Steel, terne plated.

Seat Disc - Buna-N.

Orifice - Super high strength, corrosion-resistant, aluminum.

Lever - Stamped aluminum.

Vent Screen - Stainless steel.

Seal Plug - Polyester thermoplastic UV stabilized.

Corrosion Protection

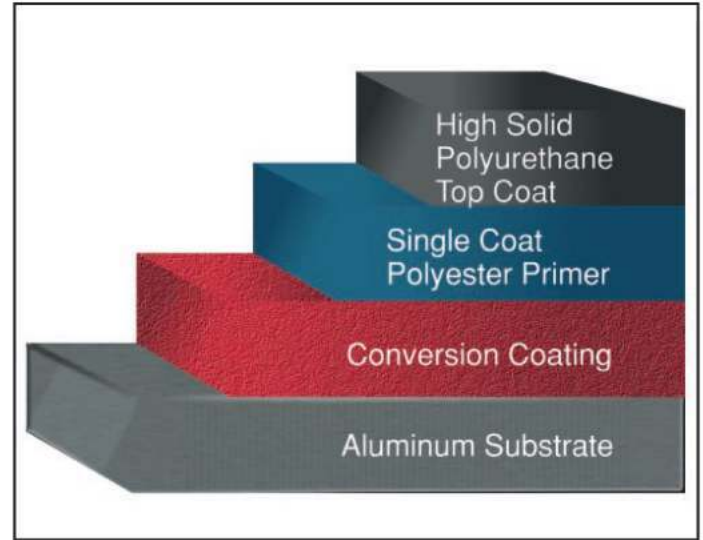

Ordering Information

- 1 Model number.
- 2 Size of inlet and outlet.
- 3 Inlet pressure, psi.
- 4 Outlet pressure, inches W.C. (or PSIG).
- 5 Flow, scfh.
- 6 Kind and specific gravity of gas.
- 7 Orifice size.
- 8 Regulator assembly position number.
- 9 Possible variation in inlet pressure for E.C. Orifice models.
Maximum _____ PSIG
Minimum _____ PSIG

Shipping Weight -

17.5 lbs/carton of four regulators

Regulator Pressure Rating

125 PSIG = Maximum recommended inlet pressure for normal service. Maximum recommended pressure may vary with orifice size.

175 PSIG = Maximum inlet pressure for abnormal or emergency service, without causing damage to regulator case.

2 PSIG = Maximum outlet pressure for normal service.

10 PSIG = Maximum outlet pressure which can be contained by pressure carrying components (no flange leakage to atmosphere except for normal relief action). ***If regulator is subjected to these conditions, it should be removed from service.***

50 PSIG = Maximum outlet pressure for abnormal service without damage to internal components. ***If regulator is subjected to these conditions, it should be removed from service.***

Due to continuous development the information in this document is subject to change.

DMC 多美時燃氣設備有限公司
DMC GAS EQUIPMENT LIMITED

**Address: Unit 11, 11/F, Tower One, Ever Gain Plaza,
88 Container Port Road, Kwai Chung, NT, Hong Kong**

Website: www.dmc-gas.com

Email: dmcsaleshk@dmc-gas.com.hk

Tel: +852 2851 2121

Fax: +852 2851 2129