

# Industrial Liquid Measurement Systems



For batching and  
challenging liquid  
phase flows

**DMC** 多美時燃氣設備有限公司  
**DMC GAS EQUIPMENT LIMITED**

Address: Unit 11, 11/F, Tower One, Ever Gain Plaza, 88 Container Port Road, Kwai Chung, NT, Hong Kong

Website: [www.dmc-gas.com](http://www.dmc-gas.com) Email: [dmcsaleshk@dmc-gas.com.hk](mailto:dmcsaleshk@dmc-gas.com.hk)

Tel: +852 2851 2121 Fax: +852 2851 2129

### Mass flow control

A mass flowmeter provides a very consistent solids content profile of coatings or sizing in web processing/manufacturing systems such as textiles, paper and composite sheeting.

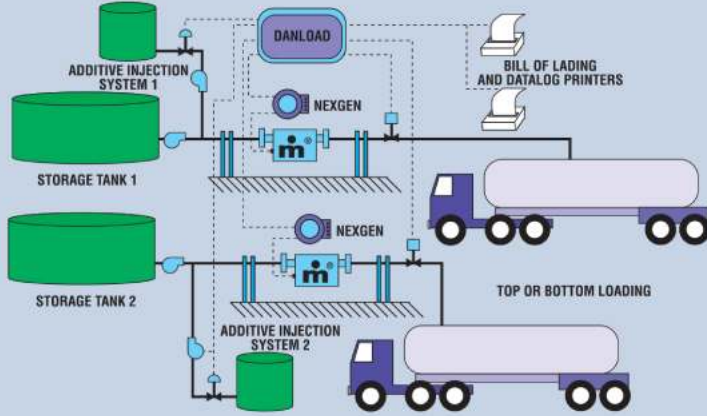
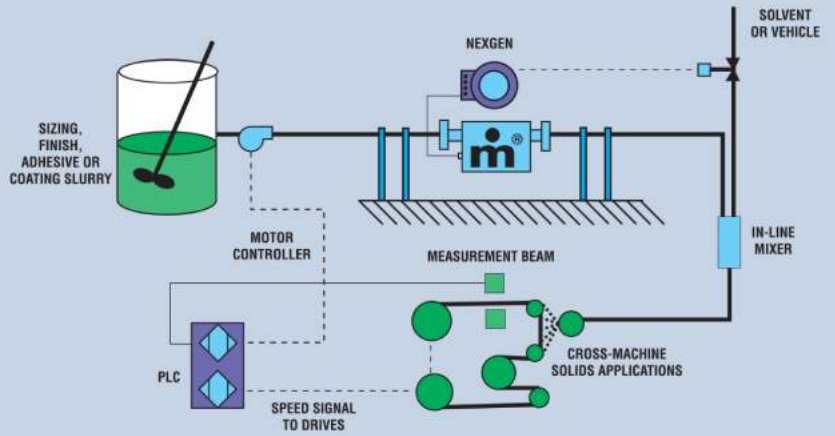

### Gasoline loading/blending

Mass flowmeters produce a mass flow signal used by the Danload to calculate and control additive injection during terminal loading operations.

### Automatic batching

Filling system controlled by BATCHMATE via remote station.

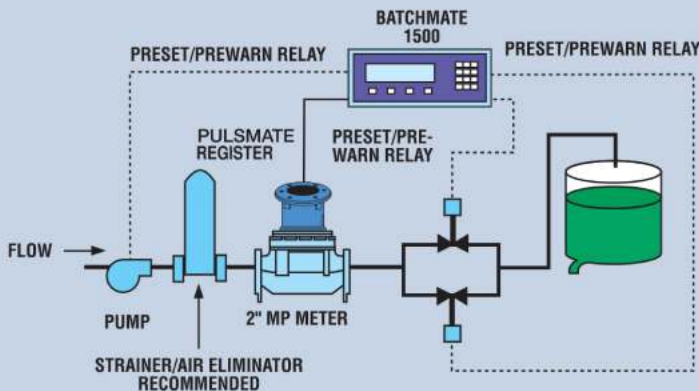
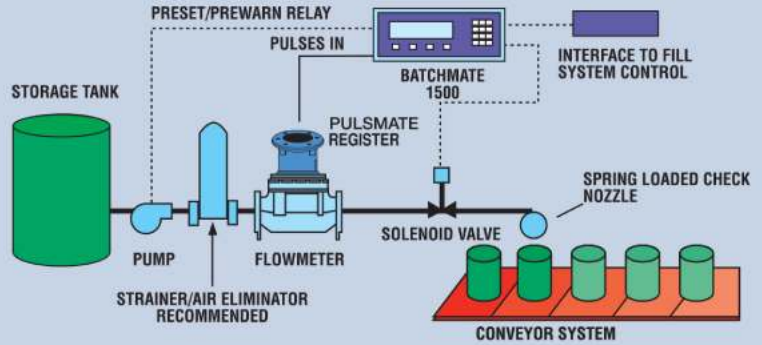

### Two-stage shut-off system

Pre-signal and final shut-off output option of the BATCHMATE prevents hydraulic shock, even at high flow rates.

# DMC 多美時燃氣設備有限公司

## DMC GAS EQUIPMENT LIMITED

Address: Unit 11, 11/F, Tower One, Ever Gain Plaza, 88 Container Port Road, Kwai Chung, NT, Hong Kong  
 Website: [www.dmc-gas.com](http://www.dmc-gas.com) Email: [dmcsaleshk@dmc-gas.com.hk](mailto:dmcsaleshk@dmc-gas.com.hk)  
 Tel: +852 2851 2121 Fax: +852 2851 2129

### Tanker loading

A BATCHMATE following a signal from a Type MP Oscillating Piston Flowmeter can operate in a two-stage shutoff mode to deliver an accurate quantity of fluid.

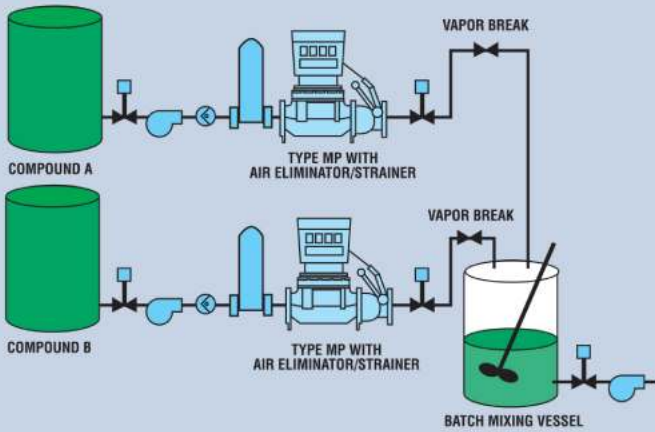
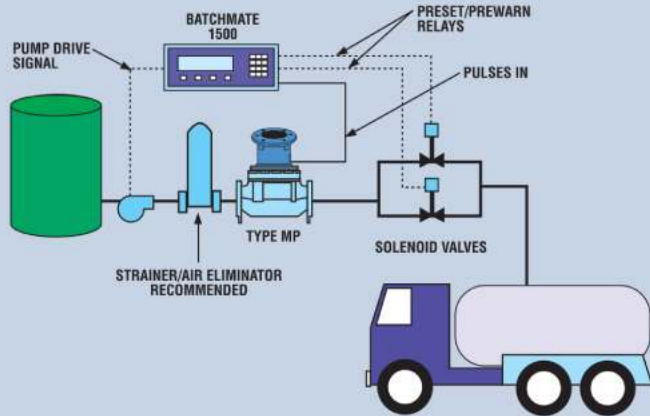

### Mechanical batching

A Type MP Oscillating Piston Flowmeter, a Series 800 Register with preset and an auto-stop valve constitute a 100% mechanical batching system—accurate and repeatable.

### Dual ingredient blending

BATCHMATE 1 delivers a preset quantity to a container, then transmits a signal to close valve No. 1 and a second signal to the "start" switch of BATCHMATE 2. After reaching its preset quantity, BATCHMATE 2 signals the conveyor drive and energizes the "start" switch on BATCHMATE 1. The sequence begins again.

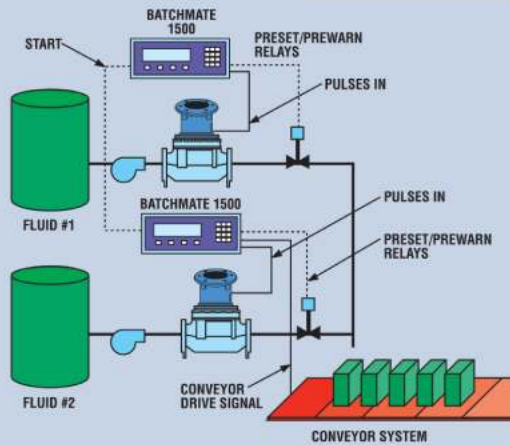

### Agricultural fluid transfer

The stainless steel Type MP Oscillating Piston Flowmeter with PULSMATE Electronic Register offers exceptional accuracy and cost efficiency for a wide range of agricultural fluids.

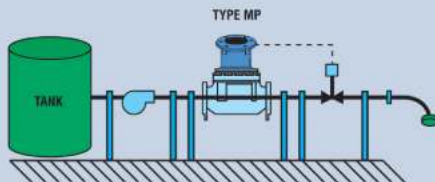

## Innovation translated into value

The true measure of innovation occurs only when technology proves itself in the field. That measure is *value*.

- "The m100 Mass Flowmeter was the only one from among several mass meters capable of producing an accurate fuel density measurement on the test stand at full throttle, producing 173 dB."
- "The Type MP Flowmeter with its static seals solved the problem of flowmeter glands hardening and causing leaks around the output shafts. This has saved us regulatory headaches."
- "After installing the Actaris Type S, we no longer had occasional foreign matter stalling the flowmeters or damaging their rotating elements. It kept us from having to install an expensive filtration system and associated controls."

Actaris liquid measurement technologies include:

- **Coriolis mass flow measurement.** Actaris mass flow technology is proven in troublesome applications, offering high accuracy in noisy, viscous flows.
- **Mechanical flowmeters.** Processors worldwide rely upon Actaris proven designs for cost-efficient accuracy and field-serviceability. Featuring magnetically coupled drives, leak-resistant static seals and tough polymer measuring elements that work well with suspended solids.
- **Electronic registration.** Actaris offers electronic registers with the flexibility to control batching locally or interface with supervisory control. Actaris is the electronic register you can grow with.

## If you can pump it...

**Actaris can measure, batch, inventory or load it, with accuracy and reliability.**

Actaris flow measurement systems have been known over a century for robust performance, ease of use and wide ranging capability. Today, with its home in Greenwood, SC, the Actaris Liquid Measurement product line forms a central part of the largest metering company in the world specializing in precision measurement.

Actaris offers its customers the experience of 8,000 employees in 60 locations worldwide, supported by sales revenues of \$750 million. The group is active in more than 30 countries with a strong presence in Europe, Asia and South America.

In your daily quest for efficiency, Actaris is the name you can trust... for accuracy and dependability, now as always.

Actaris focuses sharply on its core technology...metering products and advanced electronic systems and services that measure, communicate and process data for liquid phase flows. To capitalize on this strength, Actaris is expanding its portfolio of advanced electronic systems that provide data/information management, particularly relating to transactions and inventory control. Backing this recognized technological know-how is a solid industrial base and a strong sales force.

The NexGen® SFT 100™ Mass Flow Transmitter with Digital Signal Processing (DSP) and open architecture is easy for users to install and configure.



### From technology strengths to customer orientation

In engineering, customer service and administrative functions, customer orientation best describes our attitude. This emphasis merges the bottom-up flow of ideas with customer feedback to stimulate a lively atmosphere of focused product innovation and refinement. In manufacturing operations, Continuous Quality Improvement methods certified under ISO 9001-2000 standards ensure each operation in the plant remains within established tolerances.

The Actaris customer orientation extends to the field. Applications specialists at the Greenwood plant back up each of our field representatives. Regular factory training ensures that field technicians can keep every Actaris flowmeter providing as-new performance.

Actaris engineers design for robust performance, ease of use and wide ranging capability.



NexGen and the M-Dot logo are reg. TMs of Actaris. Other tradenames are the property of their respective owners.

## Mass measurement flexibility for challenging applications

The Actaris Coriolis Mass Flowmeter employs application-focused technology for precision mass- and density-based control over the most difficult batching and transfer flows. A large installed base represents a wide range of applications.

- Unmatched 100:1 turndown across the line
- Unequaled low pressure drop
- Patented, dual omega-shaped flow tube design has exceptional Coriolis sensitivity
- No need to sacrifice accuracy to maintain line pressure

This mass flowmeter provides excellent Coriolis sensitivity at low flow, making it ideal for viscous fluids. The Coriolis mass measurement principle gives the flowmeter high accuracy regardless of changing temperature.

Consistent accuracy under changing conditions enables the flowmeter to provide tighter process control, lower process variability and enhanced statistical process control. This pays off in reduced waste and off-spec, especially during startups and process swings. Additionally, setup and changeover times are less than with alternate methods.

The Actaris smooth omega flow path withstands abrasives and vibration better than other designs. There are no moving parts, and HASTELLOY® C-22 wetted parts are available.

Actaris offers a broad range of product capability, to flows of 6,804 kg/min (15,000 lb/min). The large-capacity m400 is available with 4", 6" and 8" flanges, with a pressure rating to 103 bar (1,500 psi). 3A-Authorized models are available through 1,450 kg/min (3,200 lb/min). This mass flowmeter is approved for custody transfer applications by mass or volume. Explosion-proof transmitters are standard, and intrinsically safe meters, accepted by

CSA/US, and LCIE, are available as an option.

To aid in your selection, ask for a free copy of our new ESP™ Expert Selection Program. Recent program enhancements include tabulating and graphing tools, an electronic application data sheet and expandable databases for data on hundreds of industrial fluids.

The Actaris Coriolis Mass Flowmeter offers direct measurement of mass flow, density and temperature in a single package.



Line sizes, mm (in.)	3 to 100 (1/8 to 4), up to 8-in. flanges
Mass flow	
Accuracy, % of rate, ±zero stability	±0.15 DATAMATE 2100™ ±0.10 NexGen® SFT 100™
Repeatability, % of rate	±0.10
Density	
Accuracy, g/cc ±	0.005 to 0.0008
Repeatability, g/cc ±	0.0005 to 0.0002
Capacity, kg/min (lb/min)	0.09 to 6,804 (0.2 to 15,000)
Turndown	100:1
Max. pressure rating, bar (psi)	69 to 248 (1,000 to 3,600)
Temperature rating, °C (°F)	-45 to 204 (-50 to 400)
Materials, wetted parts	316L SST; HASTELLOY C-22 optional

Pressure Drop Chart

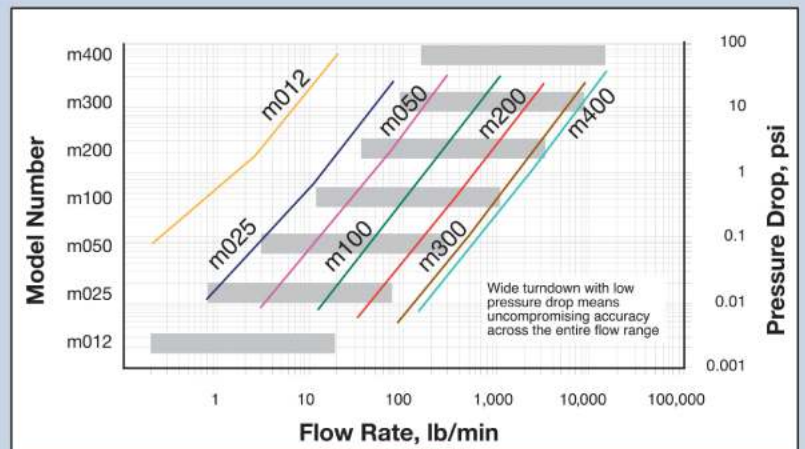

## NexGen® SFT 100™ Mass Flow Transmitter

The NexGen® SFT 100™ is the first Coriolis mass flow transmitter with Digital Signal Processing (DSP) and open architecture for easily enhanced and modified capabilities.

- Measures mass flow rate and total mass, density, temperature, standard and actual volumetric flow rate and total volume; concentration, Brix, Baumé, API and percent solids
- Patented Digital Signal Processing (DSP) technology
- Value-added design allows the user to select only the necessary options
- Weights & Measures approved for custody transfer applications
- Offers preset (two-stage) batch control in explosion-proof/flame-proof area from local keypad/display
- Standard explosion-proof enclosure

# NexGen®



The DATAMATE 2200™ Mass Flow Computer offers local control or interfacing to higher level control.



## DATAMATE 2200™ Mass Flow Computer

The DATAMATE 2200™ offers stand-alone batching control or interfacing to higher level control instrumentation.

- Measures mass flow rate and total mass, density, temperature, standard and actual volumetric flow rate and total volume; concentration and percent solids, Net Oil (option)
- Preset (two-stage) batch control functions
- RS-485 Modbus communications
- Two user-programmable alarms with high and low output for each
- Diagnostic self-check capability
- Two standard user-programmable 4–20 mA outputs
- One standard quadrature pulse output

Website: [www.dmc-gas.com](http://www.dmc-gas.com)

Email: [dmcsaleshk@dmc-gas.com.hk](mailto:dmcsaleshk@dmc-gas.com.hk)



## Coriolis mass flow custody transfer

Custody transfer by mass measurement has arrived. The Actaris Coriolis Mass Flowmeter is Weights & Measures approved for custody transfer of fuels, refined petroleum products, LPG, jet fuel, solvents, anhydrous ammonia, Freon, fertilizers, herbicides, alcohols, glycols, and other chemicals. Weights & Measures approval of mass flow technology is a significant step forward for custody transfer metering.

Mass flow measurement is not affected by changes in viscosity, density, temperature or pressure, as are volumetric measurement systems. This results in more accurate delivery under changing climatic or process conditions. Since there are no moving parts, there are no components to wear out or cause progressive inaccuracy.

The new E4000 Electronic Register for truck mounted transaction monitoring and reporting, the DATAMATE 2200 Mass Flow Computer and the NexGen SFT 100 Mass Flow Transmitter carry approvals. The approvals cover systems installed in depots and on trucks. Contact an Actaris applications specialist for specific local approvals by mass or volume.

- W&M-approved for mass and volume measurement... $\pm 0.10\%$  of rate accuracy
- No volumetric temperature compensation—measures mass directly
- Ideal for loading or off-loading of single or multiple products
- No weigh scales...cost-efficient installation, faster transfer and maximum filling
- Low pressure drop in all sizes
- Optional smart printer interface enables your choice of printer and ticket layout
- Available accessories include vapor/air eliminators and flow differential control valves

Actaris Coriolis mass flow custody transfer technology interfaces with the Actaris E4000 Electronic Register or a wide range of third party electronic registration options.



Meter	Model	Mass Flow Range, kg/min (lb/min)	
1/4"	m025	6.8–36.3	(15–80)
1/2"	m050	13.6–136	(30–300)
1"	m100	50–500	(110–1,100)
2"	m200	145–1,450	(320–3,200)
3"	m300	408–4,082	(900–9,000)
4"	m400	454–4,540	(1,000–10,000)

**DMC** 多美時燃氣設備有限公司  
**DMC GAS EQUIPMENT LIMITED**

Address: Unit 11, 11/F, Tower One, Ever Gain Plaza  
 88 Container Port Road, Kwai Chung, NT, Hong Kong

Website: [www.dmc-gas.com](http://www.dmc-gas.com)

Email: [dmcsaleshk@dmc-gas.com.hk](mailto:dmcsaleshk@dmc-gas.com.hk)

Tel: +852 2851 2121

Fax: +852 2851 2129

## Volumetric flowmeters

Mechanical volumetric flowmeters hold an important place in fluid processing. Our Type MP Oscillating Piston Flowmeter is particularly suited for nonpolar organic solvents and hazardous liquids with its leak-resistant design. The Type S Disc Flowmeter is tolerant of suspended solids that can interfere with the operation of many mechanical types.

### Type MP Oscillating Piston Flowmeter

This field-proven technology offers high environmental integrity. There are no dynamic mechanical seals and no stuffing box in the measuring chamber, providing exceptional leak resistance.

- Magnetic drive...gear train is external and easily accessible
- Capillary seal design...eliminates metal/metal contact
- Low-torque operation, even at low flow rates, for high accuracy:  $\pm 0.5\%$ , repeatability 0.1%
- Variety of engineered plastic piston materials to suit various fluid and temperature conditions

- Lightweight, compact...choice of cast iron, bronze or stainless steel
- Approved for custody transfer applications (herbicide)
- Choice of electronic or 100% mechanical batching capability...no external power source required
- PULSMATE™ Electronic Register tracks both flow rate and cumulative volume, with scalable pulse output as standard and optional totalizers and 4–20 mA analog output
- Broad mechanical register options... preset auto-stop, totalizer, pulse and analog outputs

The Type MP with PULSMATE™ Electronic Register provides anytime, anywhere process monitoring.



The Type MP, an oscillating piston, magnetic drive flowmeter, is the heart of an accurate, consistent mechanical batching system.



Size, mm (in.)	Flow Range, litres/min (gpm)
12.7 (1/2) (NPT or ANSI flange)	4–38 (1–10)
25.4 (1) ANSI	26–265 (7–70)
50.8 (2) ANSI	57–568 (15–150)
76.2 (3) ANSI	113–1,136 (30–300)



Address: Unit 11, 11/F, Tower One, Ever Gain Plaza  
88 Container Port Road, Kwai Chung, NT, Hong Kong  
Website: www.dmc-gas.com  
Email: dmcsaleshk@dmc-gas.com.hk  
Tel: +852 2851 2121  
Fax: +852 2851 2129

### Type S Disc Flowmeter

This versatile flowmeter is virtually unaffected by viscosity or flow profile disturbances. Remarkably forgiving, the Type S tolerates suspended solids that stall many other mechanical flowmeter types.

- Functional...ideal for inventory control, mechanical or electronic batching, totalizing, flow monitoring
- Durable...glass phenolic or Ryton® discs
- Pressures to 10.2 bar (150 psi), temperatures to 121°C (250°F)
- ±1% accuracy
- PULSMATE Electronic Register available for magnetic drive models (no stuffing box)
- Broad mechanical register options...preset auto-stop, totalizer, pulse and analog outputs



Size, mm (in.)		Flow Range, litres/min (gpm) <sup>1</sup>	
15.9	(5/8)	7.6–76	(2–20)
19.1	(3/4)	11.4–114	(3–30)
25.4	(1)	19–189	(5–50)
38.1	(1-1/2)	37.8–378	(10–100)
50.8	(2)	60.6–606	(16–160)

<sup>1</sup>Lower rates available on viscous applications.

### Specialized flowmeters

Actaris offers a range of flowmeters for special applications. These include the Type VLF Very Low Flow Flowmeters and an ink flowmeter for printing presses and very high pressure applications. Whatever your industrial flow measurement need, call us—we have the technology to fill your needs.

The Actaris Ink/High Pressure Flowmeter offers accurate measurement of ink consumption on printing presses.



Type VLF Very Low Flow Flowmeters are often used to improve measurement of fuel oil to boilers in steam generation systems.



Meter Type	Size, mm (in.)		Flow Range, litres/hr (gph)		Working Temperature, °C (°F)		Working Pressure, kg/cm <sup>2</sup> (PSI)		Materials, Wetted Parts
VLF 4	3.2	(1/8)	1–80	(0.25–20)	60	(140)	25	(350) <sup>1</sup>	Brass/aluminum
VLF 8	9.5	(3/8)	4–200	(1–50)	60	(140)	25	(350) <sup>1</sup>	Brass/aluminum
VLF 20	19.1	(3/4)	34–1,476	(9–390)	130	(260)	16	(225) <sup>1</sup>	Brass/aluminum
INK	15.8 x 25.4	(5/8 x 1)	0.9–9.4	(0.25–2.5) <sup>2</sup>	121	(250)	350	(5,000)	Steel/bronze/phenolic

<sup>1</sup>Maximum pressure. <sup>2</sup>Flow range in litres/min (gpm).

### If it flows, Actaris can measure it!

Actaris is committed to making its flowmeters easy to interface with your existing control systems. We offer a number of devices to provide the right registration and output signals for your needs.

When you need a flowmetering solution, Actaris and its authorized representatives stand ready to assist you. We are committed to rapid response to your inquiry with qualified engineering and applications assistance. Your order of systems or parts will be taken on a 24-hour basis and expedited to whatever degree to keep your operation running.

Contact Actaris or your local representative for detailed literature on the individual flowmeter types introduced in this brochure. We look forward to helping you maximize your process efficiency and quality!

Pulse transmitters and contact closure switches aid the configuration of batching operations.



The BATCHMATE 1500™ is a flexible, easily configured batching controller for use with Actaris mechanical flowmeters.



#### BATCHMATE 1500™ Batch Controller

- K-factor programmable to 8 places
- Pulse or analog input (with totalizing integration)
- Scaled pulse or optional 4–20 mA analog outputs
- Displays total, rate or grand total
- 20 KHz count speed
- Two-way RS-232/422 communications
- Batcher with two-stage control
- Optional 16-point linearization
- Missing pulse detection

#### Signal transmitters and switches for mechanical registers

- Contact closure and solid state square wave output
- UL- and CSA-listed explosion-proof enclosures (CE version available)
- High-resolution for small batch accuracy
- Pulse output transmitters
- Counter-activated switches for remote actuation of pumps and valves and for batch counting

The PULSMATE Electronic Register offers enhanced capabilities for new or existing Type MP and magnetic drive Type S flowmeters...combining features of localized registration and a flow computer.



#### PULSMATE™ Electronic Register

- Displays both flow rate and cumulative volume simultaneously, with optional high–low rate alarm
- Standard scalable pulse output for process monitoring anytime, anywhere
- Optional 4–20 mA analog output for remote rate indication
- Selectable totalizer models, resettable and non-resettable (cumulative)
- Retrofittable to existing magnetic drive flowmeters
- Electronic calibration for fast setup; no need for mechanical change gears
- Durable Engineering Thermoplastic Polyurethane (ETPU) housing is stable, tough and chemically inert

Flowmeter Type	Steam	Gas	Water	Slurries	Corrosives	Abrasives	Solvents/ Fuels	Max. Accuracy, % ±	Repeatability, % ±
Coriolis Mass	Yes <sup>1</sup>	Yes <sup>1</sup>	Yes	Yes	Yes	Yes	Yes	0.10 (mass) 0.0008 (density)	0.1 (mass) 0.0002 (density)
Type MP Oscillating Piston	No	No	Yes	No	Yes	No	Yes	0.5	0.1
Type S Nutting Disc	No	No	Yes	Yes	No	No	Yes	1	NA
Type VLF Very Low Flow	No	No	No	No	No	No	Yes	1.0	NA

This chart is intended as a general guide only. Contact your Actaris flowmeter representative for experienced applications assistance relating to your specific needs.

<sup>1</sup>Consult the factory for gas applications.

## Typical flowmeter applications

### Additive blending

Mass flowmeters control metering of additives with the highest possible accuracy for outstanding sheet uniformity and consistency.

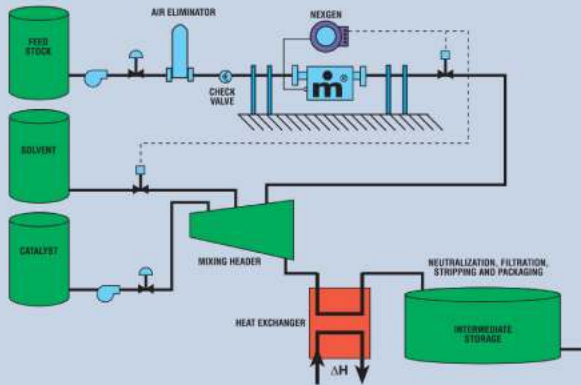
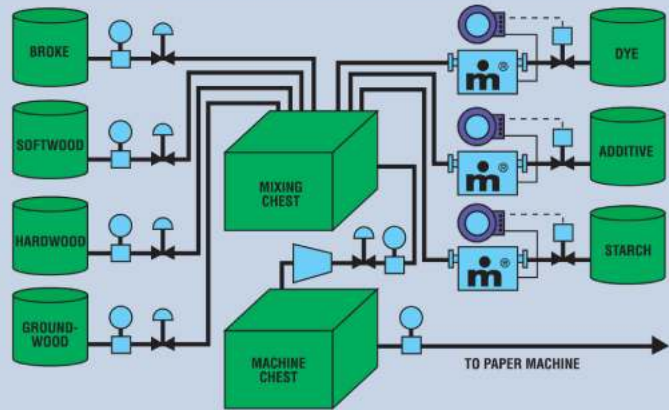

### Process control

A mass flowmeter controls precise metering of expensive catalyst, providing improved product consistency and material savings.

### Mass-based blending

Mass flowmeters excel controlling ratios of two or more starting compounds with different densities. The PLC drives the NexGen Mass Flow Transmitters to achieve the desired ratio; it also controls the valves. A third mass flowmeter loads end product with custody transfer accuracy.

